

»» Changing brake disc



INTRODUCTION

- » **Changing brake disc**
- » Changing hub unit
- » Changing brake pads
- » Changing ABS
- » Changing brake callipers
- » Changing air spring
- » Changing clamping attachment
- » Changing air bellows
- » Changing brake cylinders
- » Changing shock absorbers
- » Changing air bellow of axle lift
- » Changing silent block of air spring

INTRODUCTION

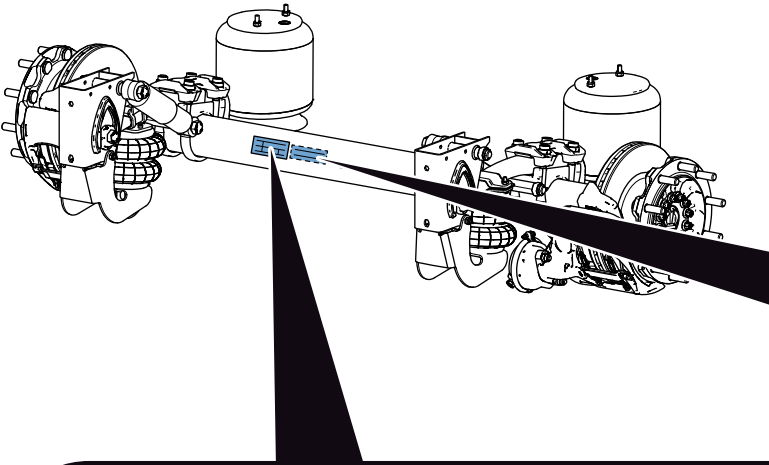

Ident No: 11010031 / D14210157

DOKTX1 09010 4345H1 2040 1300 B22ABS







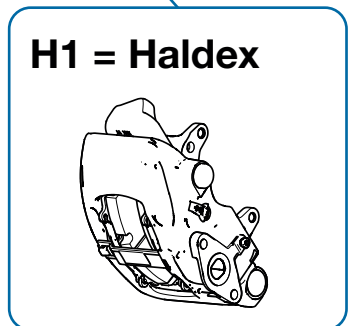
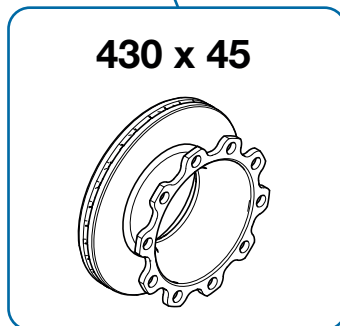
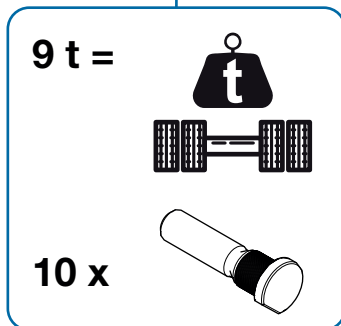
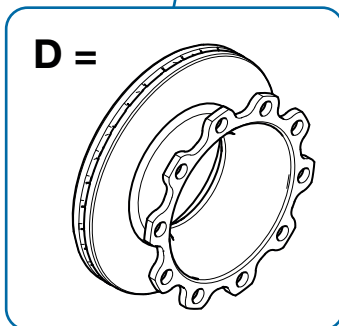







ID1-	225	stat. axle load 9.000 kg v max 105 km/h
ID2-	4345HT	
ID3-	10006,2	
ID4-	36107313	

















Made exclusively for KRONE by gigant-Trenkamp & Gele GmbH, 49413 Dinklage, GERMANY
A member of the **KRONE** - Group













INTRODUCTION

	Take notes!	
	Follow the safety instructions!	
	Attention!	
	Caution: heavy; handle properly.	
	Always wear the necessary safety equipment!	
	Always wear the necessary safety equipment!	
	Always wear the necessary safety equipment!	
	Only use tested and approved tools.	
	Follow instructions of the manufacturer!	
	axle load	
	Clicking noise is heard.	
	good	
	bad	
	O.k.	





INTRODUCTION

	Use new component.	
	Loosen with tool!	
	Tighten with required tightening torques!	
	Tighten the bolts crosswise!	
	Carefully force in or out using a hammer.	
	Push until stop!	
	loosen	
	tighten	
	Take something in by hand.	
	Take something out by hand.	
	Remove part and put it aside!	
	Don't use impact wrench!	
	clean	
	Dispose properly.	



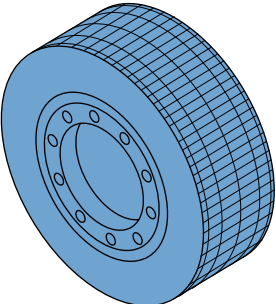

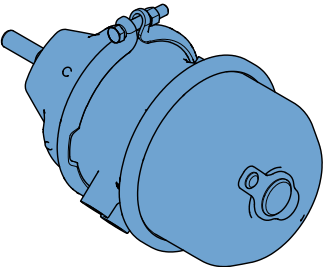

INTRODUCTION

	Check / inspect visually!	
	Check thread!	
	Check brake at brake test stand.	
	Check / inspect visually!	
	possible helping tool	
	Secure the trailer against rolling away!	
	Don't grease.	
	Turn clockwise.	
	Turn counterclockwise.	
	Secure the part using a hoisting loop and a crane.	
	Disconnect compressed air supply of trailer.	



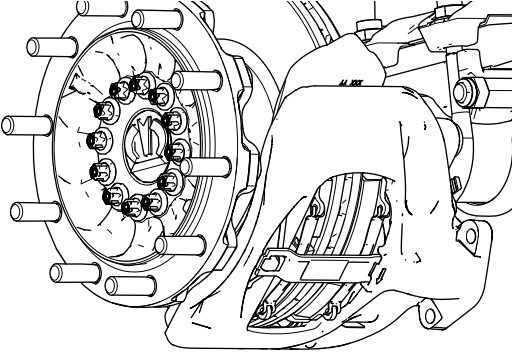
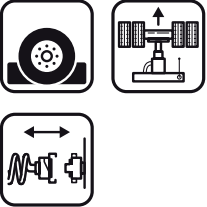
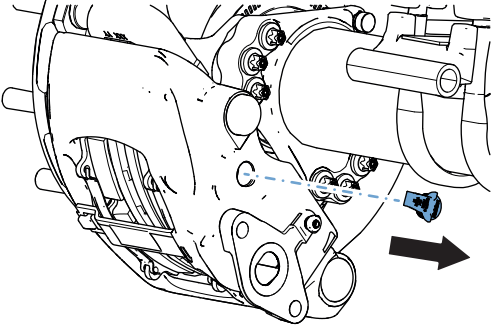

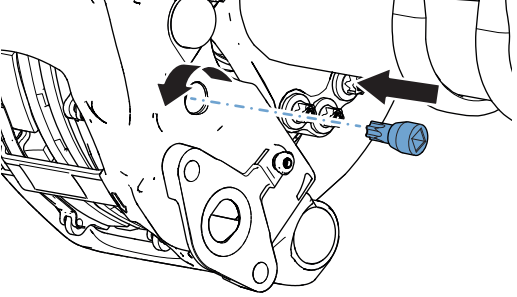





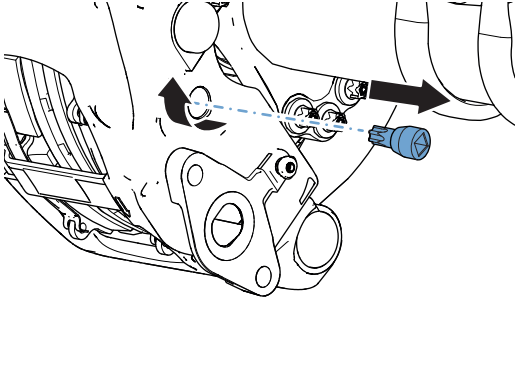

INTRODUCTION

1		 	
2		 	

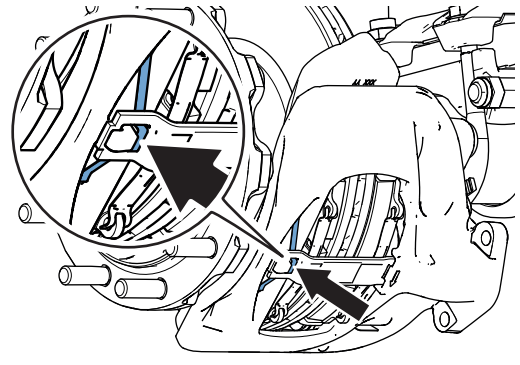
CHANGING BRAKE DISC

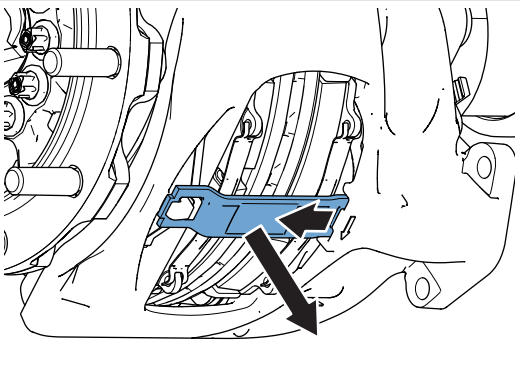
			
1			
2			
3			 <p>max. 20 Nm</p>

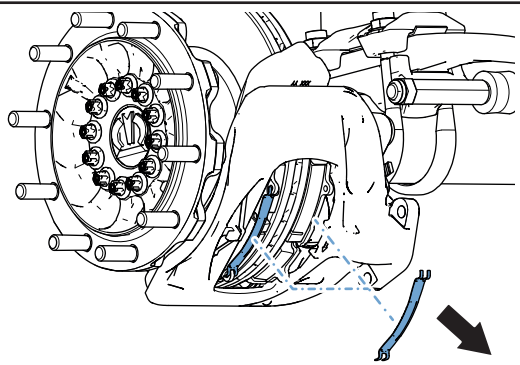
CHANGING BRAKE DISC

4		   	 <p>90° max. 20 Nm</p>
5			
6			
7			





CHANGING BRAKE DISC

8			
9			
10			
11			



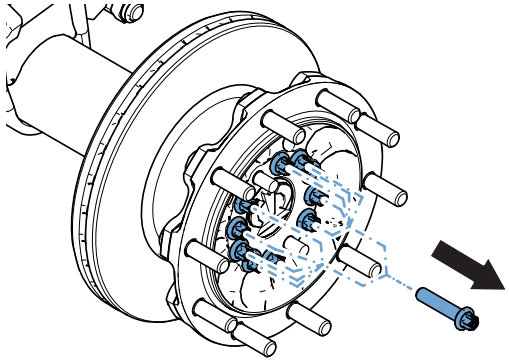

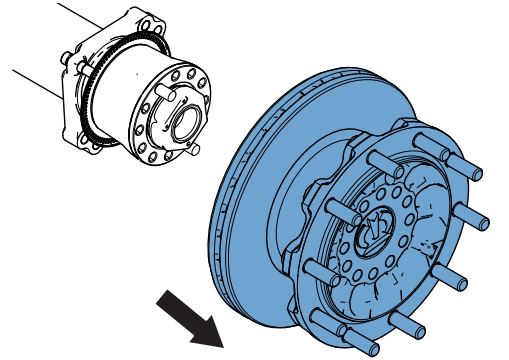
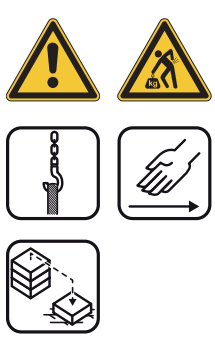
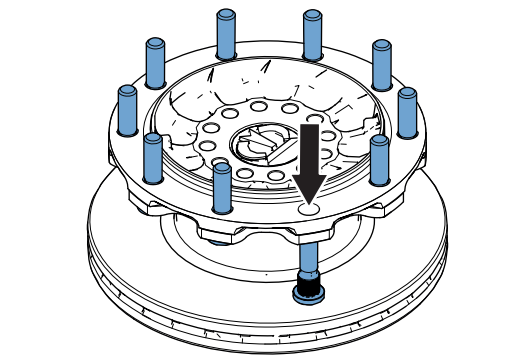

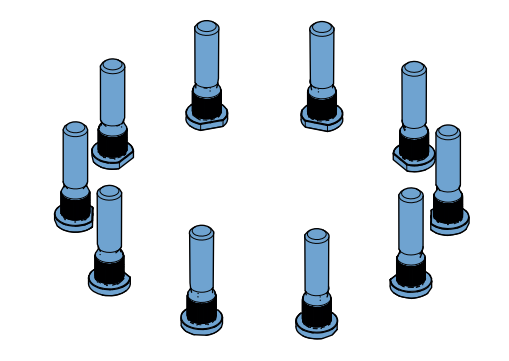
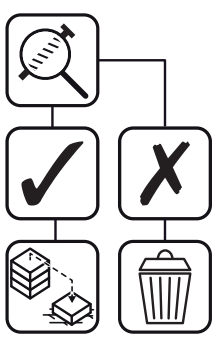

CHANGING BRAKE DISC

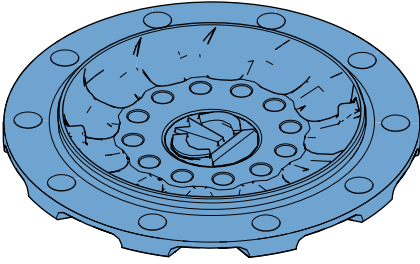
12			
13			
14			
15			<p>Krone-Nr.: 550018074</p>

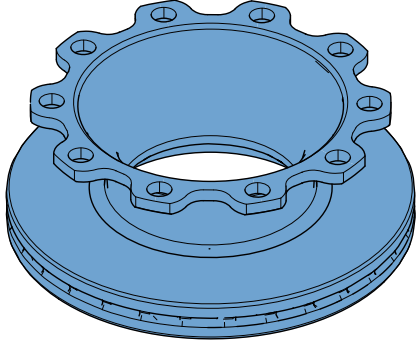
CHANGING BRAKE DISC

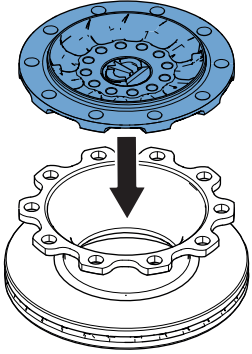
16			
17			
18			
19			

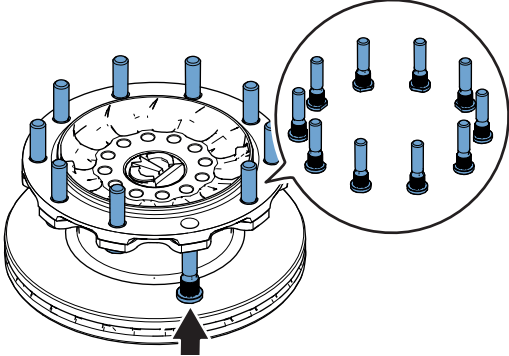
CHANGING BRAKE DISC

20			
21			
22			
23			

CHANGING BRAKE DISC

24			
25			
26			
27			

CHANGING BRAKE DISC

28			<p>470 Nm \pm 25 Nm</p>
29			
30			
31	<p>1</p>		

CHANGING BRAKE DISC

32			
33			<p>1) 30 Nm 2) 190 Nm + 60°</p>
34			
35			

CHANGING BRAKE DISC

36			
37			
38			
39			

CHANGING BRAKE DISC

40			
41			
42			

Your KRONE contact person

FAHRZEUGWERK BERNARD KRONE GMBH

Bernard-Krone-Straße 1, 49757 Werlte, Germany
Phone: +49 (0) 5951 / 209-0, Fax: +49 (0) 5951 / 24 65
info.nfz@krone.de, www.krone-trailer.com